

## Description

15-inch capacitive screen chrome-plated touch all-in-one machine, high resolution, high display brightness, high touch screen resolution, with fanless dust, aluminum alloy cooling back cover and other special structures, suitable for industry, commercial, etc.



## Highlights

- 8mm narrow-frame design
- Fully enclosed fanless rear shell
- Pure plane control
- Metal appearance material
- Green
- 7\*24H All-weather operation
- High efficiency
- Support for power-on
- Runs T3000 well in touch screen mode

## Basic parameters of display screen

Product Name	15-inch capacitive screen chrome-plated touch all-in-one
Model	LS530C-N19PL-AL2
Screen specs	15"
Response Time	5ms
Backlight type	LED
Point distance	0.297mm×0.297mm
Identification rate	1024×768/60HZ
Viewing Angle (CR>10)	R/L 130(Typ.), U/D 100(Typ)
Screen scale	4:3
Show brightness	500cd/m2
Ratio	1000:1
Backlight life	50000h
Color depth	16M
Signal input interface	LVDS

## Basic parameters of touch screen

Touch the screen	Capacitive (projected)
Touch	Fingers or a dedicated touch pen
Points	10 touch
Touch the communication interface	USB port
Touches	50 million times
Touch screen transmission	85±5%
Surface hardness	≥6H
Touch screen resolution	4096×4096

## Host configuration

Motherboard	Intel J1900 Industrial Board
CPU	New Celeron 4 Core 1.99GHz
Memory	4G
Hard disk	HdD SSD SSD 32G
Power	External power supply 12V
Card	Built-in Gigabit card
Graphics	Integrated Intel HD
Interface	VGA x 1, HDMI x 1, USB x 4, LAN x 1, COM x 2, audio input/output x 1, DC power connector x 1
Special structure	Fanless dust-proof structure, aluminum alloy thermal back cover
Common System References	win10 English Professional System
Built-in features can be added	Built-in WIFI

## Other

Normal power	≤40W
Visual size	306mm×231mm
Operating temperature	-10℃~+60℃
Housing size	351.4mm×275.4mm×48mm
Ambient humidity	20%~70%
VESA bracket hole	75mm×75mm
Weight	5.65kg
Appearance material	Metal cold-rolled plate
Industry for use	Industry, Commerce
bracket	Die-casting bracket

## Dimensions

Unit:mm

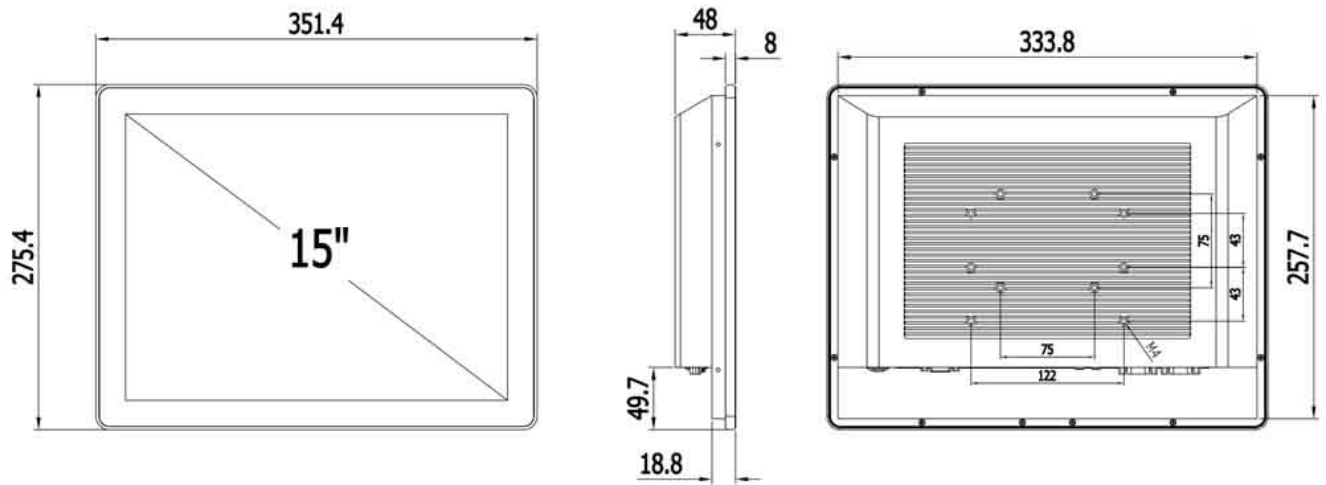

## Wall-mounted installation instructions

1. Secure the wall mount edging bracket A with expansion screws on the wall
2. Wall mount bracket B is screwmounted on the back of the all-in-one machine
3. The back bracket of the all-in-one machine is inserted into the wall bracket to complete the installation

